

TECHNICAL INFORMATION | MOBILE SCREENING PLANTS

# MOBISCREEN MS 703i EVO

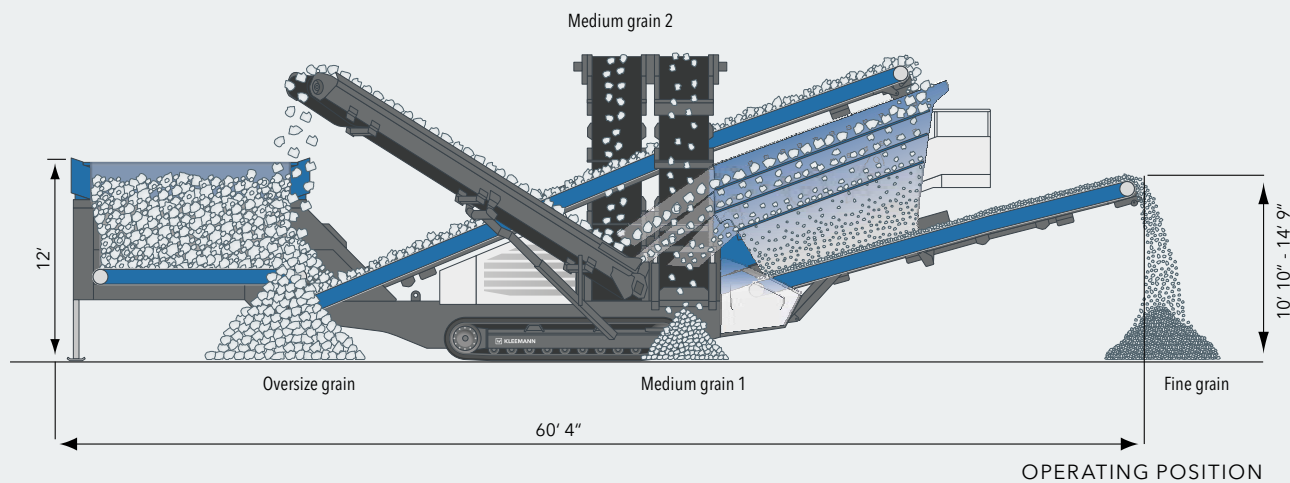



## TECHNICAL HIGHLIGHTS

- Mobile triple-deck screening unit
- Diesel-hydraulic drive
- Classifying screen
- Maximum feed size 3.94" x 6.3"

## TECHNICAL INFORMATION MS 703i EVO

### Feeding unit

Feed capacity up to approx. (US t/h)	386
Max. feed size (inch)	4" x 6.3" (13.78") <sup>1)</sup>
Feed height - foldable slotted grate (inch)	12'
Hopper volume (yd <sup>3</sup> )	10.5

### Hopper discharge belt

Width x Length (inch)	3' 11" x 11' 6"
-----------------------	-----------------

### Feeding Conveyor

Width x Length (inch)	3' 11" x 33' 10"
-----------------------	------------------

### Screening unit

Type	Triple-deck screen
Width x Length (inch)	5' 1" x 14' 9"

### Fine grain discharge conveyor

Width x Length (inch)	3' 11" x 21' 8"
Discharge height approx. (inch)	10' 10" - 14' 9"

### Side discharge conveyor, right

Width x Length (inch)	2' 2" x 33' 6"
Discharge height approx. (inch)	16' 5"

### Side discharge conveyor, left

Width x Length (inch)	2' 2" x 33' 6"
Discharge height approx. (inch)	16' 5"

### Transfer conveyor

Width x Length (inch)	2' 2" x 5' 11"
-----------------------	----------------

### Oversize grain conveyor

Width x Length (inch)	1' 8" x 29' 2"
Discharge height approx. (inch)	16' 1"

### Power supply unit

Drive concept	Diesel-hydraulic
MS 703i: Deutz (Tier 4f/Stage IV) (hp)	98

### Transport

Transport height approx. (inch)	11' 2"
Transport length approx. (inch)	54' 3"
Transport width approx. (inch)	10' 6"
Transport weight of basic plant - max. configuration (lbs)	73,900 - 90,400

<sup>1)</sup> with vibrating grate



## MOBISCREEN MS 703i EVO

As a triple-deck classifying screen, the mobile screening plant MOBISCREEN MS 703i EVO is equipped with a 75 ft squared screen box. Good transport dimensions and short set-up times characterize the plant. The plant is operated using a modern control system. As a result, all functions are easy to control and operating statuses and machine functions can be viewed at any time.

### STANDARD EQUIPMENT

- Triple-deck classifying screen
- 10.5 yd<sup>3</sup> hopper unit
- Dosing flap on hopper unit for continuous material flow
- Foldable grate, gap width 4", can be folded hydraulically (small remote control)
- Feeding conveyor, smooth belt
- Material brake for feeding conveyor prevents material rolling back
- Material brake for screen prevents feed material leaping from the upper deck
- Oversize grain conveyor, belt width 1' 8", max. discharge height 16' 1"
- Side discharge conveyors, belt width 2' 2", max. discharge height 16' 5"
- Fine grain discharge conveyor, belt width 3' 11", max. discharge height 14' 9"
- Removable, wired machine control system with the functions: crawler chassis, operation of crusher discharge conveyors and foldable grate (transport and production position), automatic mode, emergency off function, moving support feet in/out, tilt adjustment of fine grain conveyor and screen box, moving and lifting the feeding conveyor, speed setting of hopper discharge conveyor, side discharge conveyors, oversize grain conveyor

### OPTIONS

- 13 yd<sup>3</sup> hopper unit
- Wear lining made from wear-resistant steel (KRS) or rubber (for 10.5 yd<sup>3</sup> and 13 yd<sup>3</sup>)
- Vibrating grate for separating feed material, gap width of upper deck 4 yd<sup>3</sup>, gap width of lower deck 1.26" - 3.54"
- Feeding conveyor, rubber cleated belt prevents material rolling back
- Oversize grain conveyor can be configured on the left or right, belt width 1' 8", discharge height 16' 1" (no retrofit possible)
- Belt cover for the feeding conveyor or fine grain discharge conveyor
- External power supply - for efficient mains operation, possible to change between two energy sources: own propulsion (diesel engine) or external power supply
- Start-Stop system for low consumption in idle phases
- Radio remote control: crawler chassis, oversize grain conveyor, slotted grate, emergency stop
- Remote control for foldable grate, in addition to cable control (omitted if plant has radio remote control)
- Line coupling for interlinking with other KLEEMANN plants
- Large selection of screen surfaces for all screens with different mesh widths
- Anti-clogging ropes for use with sticky material
- Water spray system for dust reduction
- Lighting, halogen or LED



**SPARE PARTS**

Efficient operation of the machine also requires the selection of the right wear parts. The KLEEMANN original parts are optimally designed for the requirements of users and the machine. They are characterized by a long service life, excellent quality, good availability, and simple assembly. With application know-how and expertise and competent advice, we help our customers to find the optimal wear part for their individual application.

**APPLICATION-DEPENDENT WEAR PARTS**

<p><b>Screen surfaces</b></p>		<ul style="list-style-type: none"> <li>☒ Screen surfaces available in different mesh shapes, wire qualities and thickness:                     <ul style="list-style-type: none"> <li>&gt; Square mesh</li> <li>&gt; Rectangular mesh</li> <li>&gt; Harp screens (G-harp, W-harp, S-harp, Varia harp)</li> </ul> </li> </ul>
<p><b>Scraper ledges</b></p> <p>Front scrapers</p> <p>Wedge strippers</p>		<ul style="list-style-type: none"> <li>☒ Wedge strippers to protect the conveyor belts</li> <li>☒ Reduction in wear with abrasion-resistant plastics</li> <li>☒ Precise scrapers guarantee less material loss</li> <li>☒ Available for:                     <ul style="list-style-type: none"> <li>&gt; Oversize grain conveyor (no front scraper, instead rapper pulley)</li> <li>&gt; Side discharge conveyor (no front scraper, instead rapper pulley)</li> <li>&gt; Fine grain discharge conveyor</li> <li>&gt; Transfer conveyor (no wedge stripper)</li> <li>&gt; Feeding conveyor, smooth</li> <li>&gt; Hopper discharge conveyor</li> <li>&gt; Cleated belt (no front scraper, instead rapper pulley)</li> <li>&gt; Feeding conveyor, cleated belt (no front scraper, instead rapper pulley)</li> </ul> </li> </ul>
<p><b>Conveyor belts</b></p>		<ul style="list-style-type: none"> <li>☒ Closed, multilayer conveyor belts are suitable for all requirements and increase the capacity of plants</li> <li>☒ Cleated belt with solid rubber edges ensures optimal material handling</li> <li>☒ Elastic rubber pads mute impacts from different materials</li> <li>☒ Smooth version or cleated belt</li> </ul>
<p><b>Conveyor belt rollers</b></p>		<ul style="list-style-type: none"> <li>☒ High-quality rollers in the belt conveyors for transporting heavy material</li> <li>☒ Simple maintenance on site thanks to easily replaceable rollers</li> <li>☒ Available in different versions:                     <ul style="list-style-type: none"> <li>&gt; Support roller for feeding</li> <li>&gt; Lateral guide roller</li> <li>&gt; Return roller</li> </ul> </li> </ul>

More information can be found online at [www.partsandmore.net](http://www.partsandmore.net) or in our Parts and more catalog