

A WIRTGEN GROUP COMPANY



Wheeled Paver

SUPER 2003-3i



PERFECT IN ALL CLASSES

The right paver for every job

VÖGELE's seamless product range is considered unique in the industry. Whether a service road or a motorway, an airfield or a race track, a new construction or a rehabilitation job, that's why the hot or cold asphalt customers will find the right machine in our paver range for every paving task.

VÖGELE PRODUCT RANGE

MINI CLASS

- > Maximum paving width
10 ft. 6 in. (3.2 m)
- > Maximum laydown rate
275 tons/h (250 tonnes/h)

COMPACT CLASS

- > Maximum paving width
13 ft. 9 in. (4.2 m)
- > Maximum laydown rate
385 tons/h (350 tonnes/h)

UNIVERSAL CLASS

- > Maximum paving width
32 ft. 10 in. (10 m)
- > Maximum laydown rate
770 tons/h (700 tonnes/h)

HIGHWAY CLASS

- > Maximum paving width
42 ft 8 in (13 m)
- > Maximum laydown rate
1,540 tons/h (1,400 tonnes/h)

SPECIAL CLASS

- > SprayJet

HIGHLIGHT OVERVIEW

Perfectly equipped

DRIVE

01 Drive technology

> Powerful engine complying with US EPA standard Tier 4f.

02 VÖGELE EcoPlus

> The VÖGELE EcoPlus low-emissions package significantly reduces fuel consumption and noise levels.

03 Drive concept

> Innovative and reliable drive concept for accurate tracking.
> Significantly smaller turning radius due to Pivot Steer steering brake.

QUALITY

04 Daily maintenance-free paver

> Daily maintenance-free paver with auto-lubrication and more.

05 Niveltronic Plus - the System for Automated Grade and Slope Control

> Fully-integrated system perfectly matched to the machinetechnology of VÖGELE road pavers.
> Wide range of sensors for flexible use in all fields of application.
> User-friendly operation and monitoring of all Niveltronic Plus functions.

MATERIAL MANAGEMENT

06 Receipt of mix

> Advanced design provides precise material handling.
> Optimum feeding with mix thanks to the large material hopper.

OPERATION

07 ErgoPlus 3 operating system

> ErgoPlus 3 with numerous additional ergonomic and functional advantages.

VERSATILITY

08 Wide range of applications

> 10-foot wheeled Highway Class paver with a large range of applications and paving widths up to 25 ft. 6 in. (7.75 m).

09 The right screed for every application

> The paver can be combined with the VF 600, VR 600 or AB 600 Extending Screeds.





01



02



03



04



05



06

SUPER 2003-3i

The versatile Highway Class wheeled paver

With the SUPER 2003-3i VÖGELE has developed an entirely paver specially for the North American market. The wheeled SUPER 2003-3i is designed primarily for use in highway construction and large-scale commercial applications, which are all about power and productivity. With a powerful, 6-cylinder engine rated at 250 hp (186 kW) and high-output hydraulic drives, it is fully equipped for these jobs.

The SUPER 2003-3i also comes with the popular ErgoPlus 3 operating system, which has been enhanced with a number of ergonomic and functional features. With its mounting system, the paver operator's console can be shifted conveniently and easily between the right and left sides of the operator's stand during operation. In addition, it has a large color display that ensures good readability even in poor lighting conditions. The screed operating consoles have been completely redesigned, making operation of this "Dash 3" machine even easier for the entire paving crew.

With its Highway Class paver, VÖGELE also offers the right screed for every application. The SUPER 2003-3i can be combined with the VF 600, the screed with front-mounted extensions, as well as the VR 600 and AB 600, two screeds with rear-mounted extensions. The AB 600 Extending Screed is equipped with both a vibration system and tamper, meaning it can achieve higher compaction. It is ideal for placing recycled materials or RCC applications. All of these features make this Highway Class machine a truly SUPER paver!



01 10-foot wheeled Highway Class paver with a large range of applications.
02 The VÖGELE EcoPlus low-emissions package significantly reduces fuel consumption and noise levels.
03 ErgoPlus 3 with numerous additional ergonomic and functional advantages.

04 Significantly smaller turning radius due to Pivot Steer steering brake.
05 Optimum feeding with mix thanks to the large material hopper.
06 The right screed for every application. The paver can be combined with the VF 600, VR 600 and AB 600 Extending Screeds.

POWERFUL AND VERSATILE

Given its enormous tractive effort and high laydown rate, the SUPER 2003-3i is the ideal machine for paving in large widths. In order to achieve an optimal paving result for every kind of application, VÖGELE offer screeds which operate with high precision. Several screed options are available for the SUPER 2003-3i, featuring different equipment with compacting systems. The paver can be combined with the VF 600 for multivariable width applications, the VR 600 for mainline applications and the AB 600 screed, with rear-mounted extensions, achieves higher compaction thanks to vibration and tamper. This screed is particularly suited for placing cold RAP (Reclaimed Asphalt Pavement) for roadbase and polymer modified asphalt.



01



02



03



04

- 01 Pavement rehabilitation on access roads
- 02 Asphalt paving on surfaces used for industrial purposes
- 03 Pavement rehabilitation on municipal roads
- 04 Asphalt paving on combined foot and cycle paths

STATE OF THE ART DRIVE TECHNOLOGY

Three main components define the power unit of a SUPER 2003-3i: its modern, liquid-cooled diesel engine, a splitter gearbox flanged directly to the engine and a large cooler assembly.

The driving force in this power pack from VÖGELE is its diesel engine. The six-cylinder engine delivers 250 hp (186 kW) at 2,000 rpm. Yet the fuel-saving ECO mode is sufficient for many applications. And even then, the SUPER 2003-3i still has a full 235 hp (175 kW) at its disposal. Moreover, the machine generates even less noise when running at just 1,700 rpm.

A large cooler assembly ensures that the power unit always delivers its full output. With innovative air routing and a variable-speed fan, temperatures are continually maintained within the optimum range, significantly extending the service

life of both the diesel engine and the hydraulic oil. A further advantage is that the machine can operate without difficulty in all climate regions worldwide.

All hydraulic elements are supplied with hydraulic oil directly from the splitter gearbox, the advantage being that all pumps and valves are combined in one spot that is easily accessible for maintenance work.

Even the powerful generator for screed heating is flanged directly onto the splitter gearbox. Its integrated oil cooling system makes it completely maintenance-free and very quiet.

250 hp (186 kW)
diesel engine output

ECO mode at 1,700 rpm
reduces operating costs

85 gal. (320 liters)
Capacity fuel tank

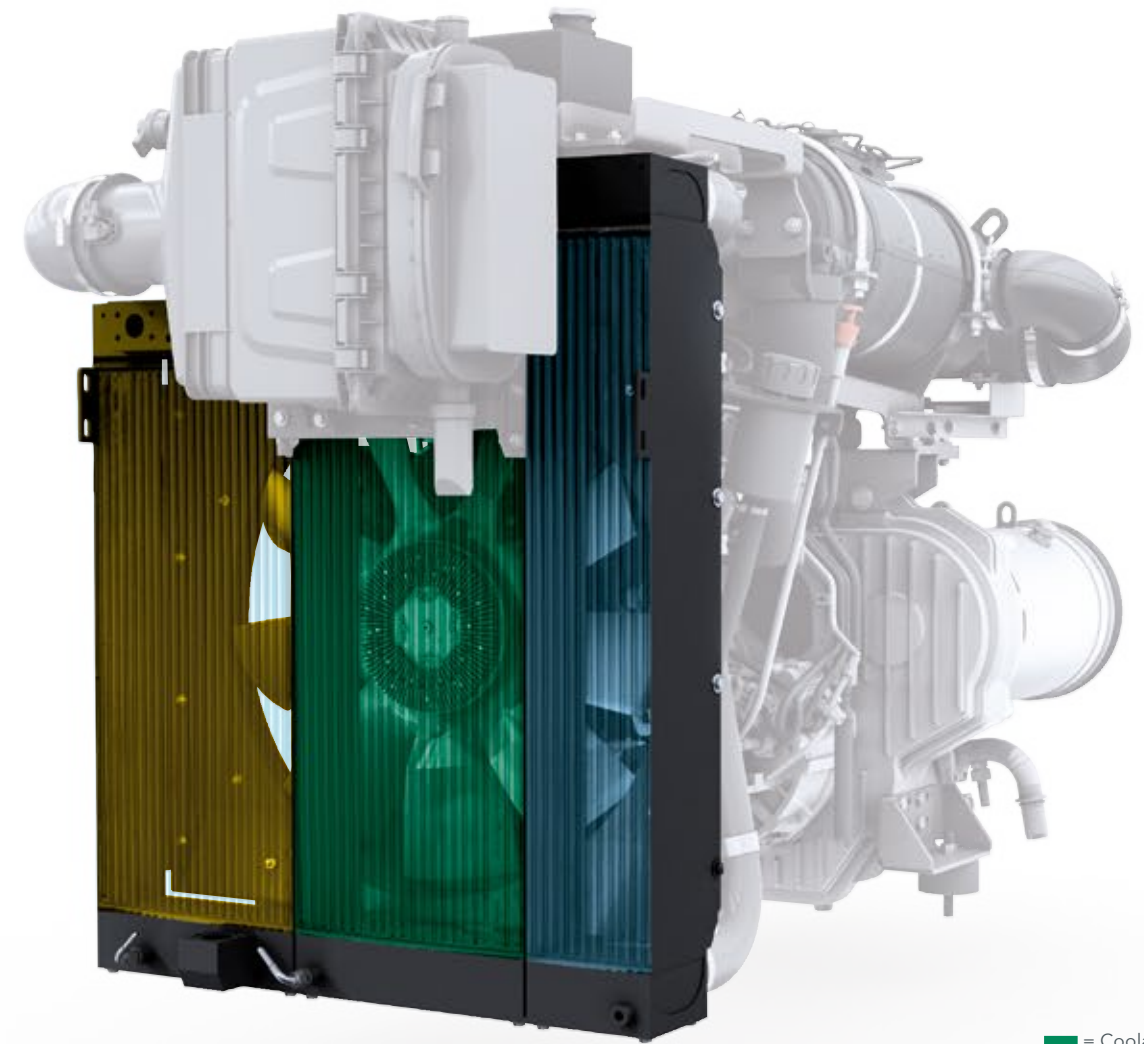

■ = Coolant
■ = Charge air
■ = Hydraulic oil

> The large cooler assembly is made up of three parts. It ensures that engine coolant, charge air and hydraulic oil are maintained at the optimum temperature.

> The fuel tank holds 85 gal. (320 liters), more than enough for a day's work. The SUPER 2003-3i additionally has a DEF tank with sufficient capacity.

> A powerful, oil-cooled generator with direct drive ensures rapid, uniform heating of the screed. The generator is directly driven by the splitter gearbox and therefore maintenance-free.

> Self-diagnostics and sensors for all engine vitals eliminate daily checks. Simply put, the engine is daily maintenance-free.

VÖGELE > GOOD TO KNOW

Exhaust emissions after-treatment and VÖGELE EcoPlus

On engines of exhaust emission standard US EPA Tier 4f, exhaust emissions after-treatment is provided by the diesel oxidation catalyst (DOC) and a selective catalytic reduction (SCR).

VÖGELE EcoPlus furthermore significantly reduces emissions. This package is capable of reducing consumption and CO₂ emissions by up to 25% and likewise reduces noise emissions.

VÖGELE ECOPLUS

Less is more

It goes without saying that our road pavers conform to the applicable emissions directives, but we like to go much further. That's why the machine concept of the "Dash 3" generation uses environmentally friendly innovations in machine technology, resulting in lower consumption, lower emissions and lower costs.

One of these innovations is the VÖGELE EcoPlus low-emissions package. Fuel savings of up to 25% can be achieved with VÖGELE EcoPlus, depending on the application and capacity utilization of the paver. That doesn't just result in considerable savings for the contractor - it is good news for the environment, too. That's because every liter of fuel saved reduces carbon dioxide (CO₂) emissions.



25% fuel saving



25% less CO₂ emitted



Lower noise emissions



VÖGELE > GOOD TO KNOW



The technical innovations



Splitter gearbox with ability to disengage hydraulic pumps

When the paver is stationary, all the hydraulic pumps needed for "traction", "conveyors and augers" and "compaction" are disengaged automatically. The result? Lower fuel consumption.

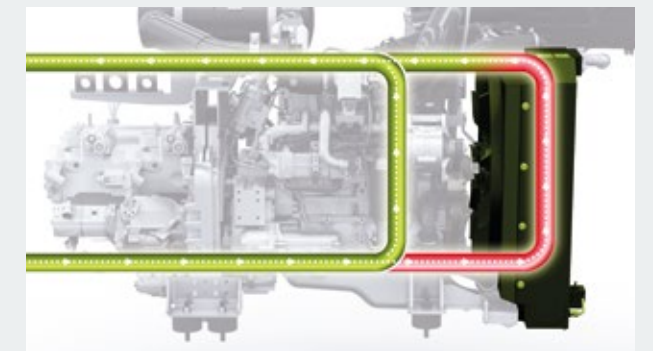

Controlled hydraulic oil temperature circuit

A bypass circuit gets the hydraulic oil to its optimum operating temperature very quickly, enabling rapid, fuel-saving operation of the paver.



Variable-speed fan

The variable-speed fan automatically adapts to the engine load and the ambient temperature. This type of drive saves energy and reduces noise emissions.

MOBILITY ON WHEELS

With its high tractive power, the wheeled paver SUPER 2003-3i perfectly combines high paving performance with maximum mobility. This is assured by powerful separate hydraulic drives in the powered wheels. They ensure maximum traction when paving and allows the paver to maneuver quickly on the job site at speeds of up to 12 mph (20 km/h).

- > Maximum power and torque from hydraulic drives.
- > Separate hydraulic drives are provided for each of the rear wheels. Two or four powered front wheels are available as options.
- > Electronic traction management ensures optimum tractive effort and protects the engine against overload.

Optimum traction
even on difficult terrain

Pivot Steer steering brake
reduces the outside turning circle to 18 ft. 4 in. (5.6 m)

Travel speed
12 mph (20 km/h)

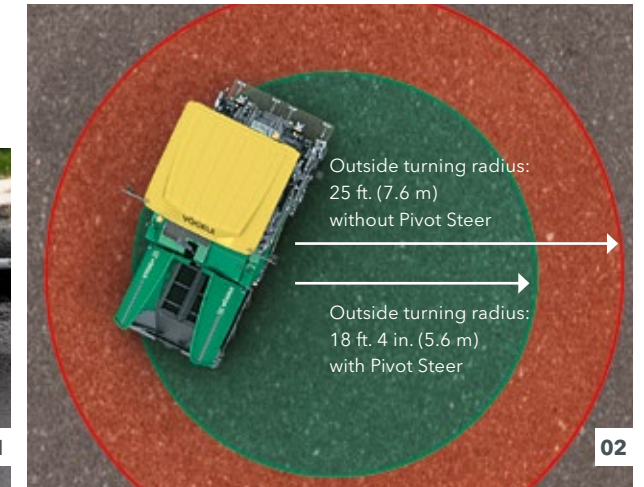

- 01** Continuous ground contact is assured by the front wheels mounted on bogies.
- 02** Extreme maneuverability thanks to "Pivot Steer". The rear inside wheel is automatically slowed down hydraulically when "Pivot Steer" is activated. This minimizes the outside turning radius to not more than 18 ft. 4 in. (5.6 m) for positioning maneuvers and paving.

> Continuous ground contact is assured by the front wheels mounted on bogies. They provide for a permanent ground contact of the wheels also when working on an uneven base.

> Rapid transport under its own power at up to 12 mph (20 km/h) – a feat the SUPER 2003-3i is optimally equipped for. All paving functions are automatically deactivated when "Maneuvering" mode is selected.



EXTRA LARGE MATERIAL HOPPER AND EASY MATERIAL FEED

A continuous flow of mix is key to ensuring uninterrupted and high-quality paving. That is why we attach such importance to professional material management when designing our pavers.

Thanks to its large material hopper and conveyor tunnel, the SUPER 2003-3i can be supplied with mix easily and quickly. The high-performance and precision systems that convey and spread the material support high laydown rates and consistent quality.

The hydraulically operated hopper apron prevents material spills during truck exchanges. It directs the material inside the hopper directly onto the conveyors, so no hand work is required. All of the mix is properly conveyed to the screed.

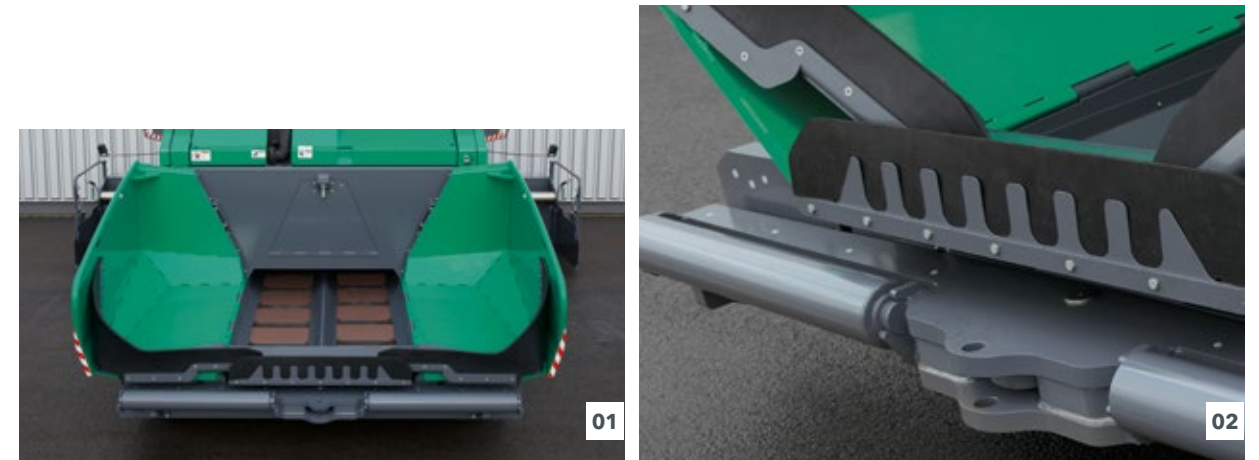

01 Independently operated hopper wings.
02 Large oscillating push-rollers can be set to 2 different positions for convenient and shock-free docking of feed vehicles even in curves.

> The large material hopper holds 16.5 tons (15 tonnes) and is dimensioned so that plenty of mix is stored at all times. Two cylinders per side provide smooth operation of the hopper wings.

> Sloped inner design of the hopper for an optimal flow of material to prevent segregation.
 > Easy feeding with mix thanks to low material hopper, wide hopper wings and sturdy rubber flashing fitted to the hopper apron.



VÖGELE > GOOD TO KNOW

Truck hitch (Option)

Keeps the truck dumping mix into the hopper in contact with the paver. This reliably prevents loss of mix during transfer.



Large material hopper
with a capacity of 16.5 tons (15 tonnes)

Deep and wide hopper sides
for especially straightforward material feed

Push-rollers
oscillating

PRECISION MATERIAL DELIVERY PREVENTS SEGREGATION

Thanks to effective spreading of the material, the SUPER 2003-3i always has an optimal head of mix in front of the screed to meet the demands of every paving situation.

The wide conveyor tunnel and powerful, hydraulic separate drives on the conveyors and augers support high laydown rates of up to 1,540 tons/h (1,400 metric tons/h).

> Proportional control and continuous monitoring of conveyors and augers guarantee a constant head of material in front of the screed.

> Inclined conveyors from the front to the rear of the machine provide ideal delivery of the material to the augers.



- 01** Narrow conveyor guard in the material hopper guarantees uniform material flow.
- 02** The optional Power Tunnel is perfect for changing paving widths. The hydraulically adjusted limiting plates adapt to the screed width automatically, ensuring an optimal head of mix in front of the screed all the way to the end gates, even when the screed extensions are fully moved out.



> Large, 16 in. (40 cm) diameter auger flights with precision pitch ensure excellent spreading of the material when paving in large widths or at lower engine rpm. VÖGELE's unique flight design provides prolonged service life versus standard flight designs.

> Narrow conveyor guard in the material hopper guarantees uniform material flow.

VÖGELE > GOOD TO KNOW

Adjustable augers

Hydraulically adjustable augers are infinitely variable in height within a range of 6 in. (15 cm). Hydraulic auger height adjustment (including bearing boxes and limiting plates for the auger tunnel) provides optimal spreading of the material even when paving thin layers or on sections where thickness varies.

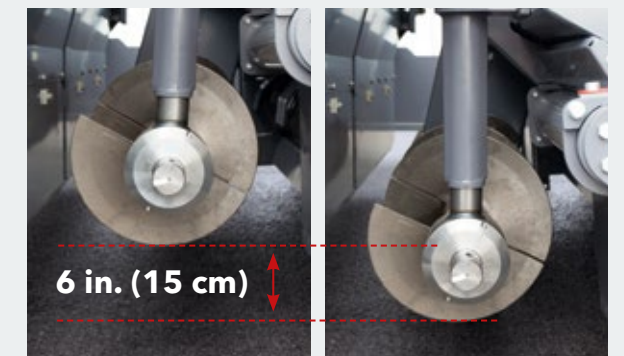



THE ERGOPLUS 3 OPERATING SYSTEM

Improved efficiency, reliability and convenience

Even the very best machine with the most advanced technology can only really show its strengths if it can be operated easily and as intuitively as possible. At the same time, it should offer an ergonomic and safe working environment for the operating team. Therefore, the ErgoPlus 3 operating system focuses on the operator. With VÖGELE pavers, the operator consequently retains full control over the machine and construction project.

On the following pages you will find detailed information on the extensive functions of the ErgoPlus 3 operating system. ErgoPlus 3 encompasses the operator's stand, the paver operator's console, the screed console and Niveltronic Plus, the System for Automatic Grade and Slope Control.



THE PAVER OPERATOR'S ERGOPLUS 3 CONSOLE

Clearly arranged in line with experience from the field

The paver operator's ErgoPlus 3 console has been designed according to practice-related principles. All controls are clearly arranged. Paver functions are clustered in logical groups so that operators find their controls just where they would expect them to be.

On the ErgoPlus 3 console, all push-buttons are easily identifiable by touch even when wearing work gloves. Once a button is pressed, off you go thanks to the "Touch and Work" principle. This means that a function is executed directly - without the need to confirm.



01 Conveyors and augers, traction

All controls for the conveyor and auger are located here. The traction main switch, the operating mode selector and the setpoint adjuster for the pave speed are also included in this function group.

02 Material hopper and steering

This function group includes the controls for the material hopper, the steering and the diesel engine. Various options are also operated from here.

03 Screed functions

All controls for the screed are grouped at the centre of the paver operator's console.

04 Display of the paver operator's console

The redesigned color display has a high-contrast user interface ensuring brilliant readability even in poor lighting conditions. Vital information is shown on menu level 1, such as the positions of the screed tow point cylinders or the material level in the conveyor tunnel. Further paver functions such as speeds for tamper and vibration or feed rates for the conveyors can easily be set up via the display, too. And the display gives access to machine-related information such as fuel consumption or service hours.

05 Safe operation during the night

Glarefree backlighting comes on automatically as darkness sets in so that the paver operator can also work safely on night-time jobs.



CONVEYORS AND AUGERS, TRACTION

Module 1

01 Reversing conveyor movement

In order to avoid mix dropping from the conveyors during a move of the paver on the job site, conveyor movement can be reversed at the push of a button. Reverse movement, transferring mix from the rear of the conveyor tunnel back inside, takes place for a short time only and stops automatically.

02 Automatic functions

For conveyors and augers, operators can easily select Manual mode or Automatic mode. When selecting Automatic mode for the augers, sensors installed for the material level in the auger tunnel provide that exactly the desired amount of mix is spread in front of the screed.

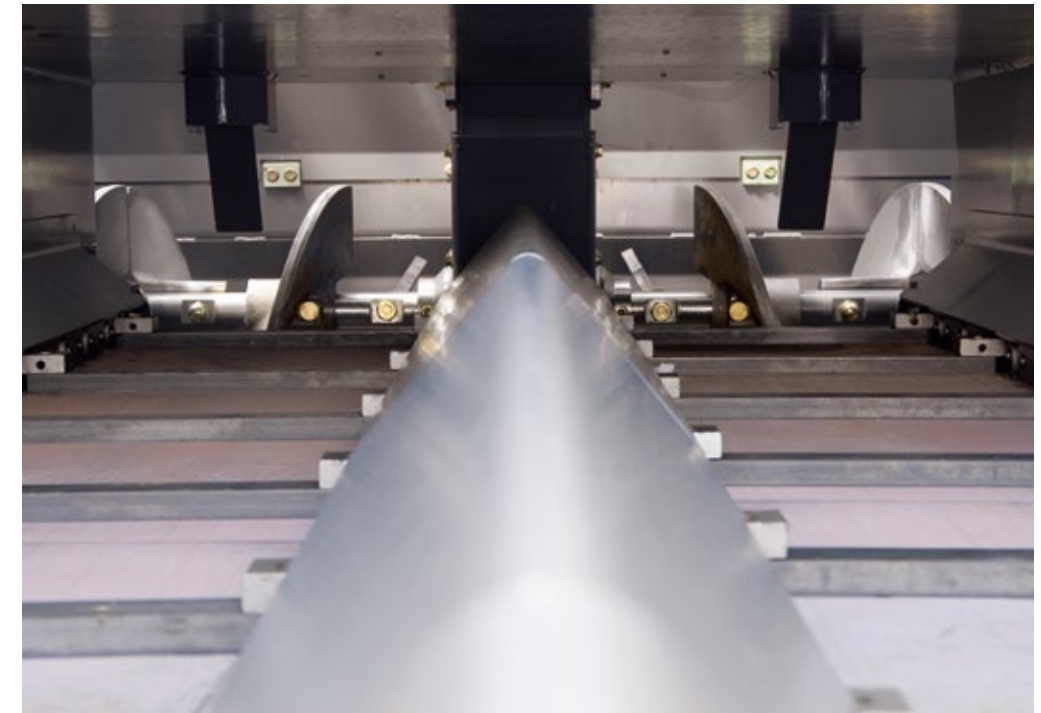

The conveyor can be reversed at the touch of a button. Return transport of the mix is automatically stopped. The conveyor can be switched to the no-load function just as quickly.



01 Reversing conveyor movement

02 Automatic functions

03 No-Load function

04 Choice of operating modes for the paver

03 No-Load function

The No-Load function is provided for the warm-up or cleaning of conveyors, augers and tamper.

04 Choice of operating modes for the paver

On the ErgoPlus 3 console, 5 different operating modes for the paver are available to select from. By pressing the arrow buttons, up or down, the operator changes modes in the following order: "Road Travel", "Neutral", "Job Site", "Positioning" and "Paving". An LED indicates the mode selected. When leaving "Pave" mode, a smart Memory feature stores the last settings for paver functions so that, when resuming work after a move of the paver on site, these settings are restored automatically.

MATERIAL MANAGEMENT

Module 2

01 Choice of engine speed ranges

For the engine, there is a choice of three modes to select from: MIN, ECO and MAX. To switch modes for engine rpm, all the operator needs to do is press the arrow buttons, up or down. In ECO Mode, the engine delivers sufficient power for a great number of paving applications. Operating in ECO Mode reduces noise emission and fuel consumption considerably.

02 Hopper wings and hydraulic hopper apron

The hydraulically operated hopper apron prevents spills of material when changing feed trucks. The two hopper wings can be folded separately or both together at the push of a button.



- 01 Choice of engine speed ranges.
- 02 The two hopper sides can be folded separately or both together at the push of a button.
- 03 Truck Hitch is available as an option.



03 Truck Hitch (Option)

Keeps the truck dumping mix into the hopper in contact with the paver. This reliably prevents loss of mix during transfer.

- 01 Choice of engine speed ranges
- 02 Independently operated hopper wings
- 03 Truck Hitch (Option)



SCREED FUNCTIONS

Module 3

All the key screed settings can be made from the paver operator's console. The screed can be raised or lowered here, each of the two sides of the screed extended or retracted or the angle of the screed adapted to suit conditions. This means the paver operator, too, has access to the screed at all times.

01 Screed Lock

When the paver is in the transport position, the screed is secured by locking bolts. When the screed is raised, the two locking bolts can be retracted by the hydraulic screed lock at the touch of a button.

02 Screed Heating

In order to optimise compaction and produce a smooth surface texture, all compacting elements are heated across full screed width. A simple touch of a button is all it takes to switch screed heating on or off. To ensure the screed heating system is working properly, an automatic function check is carried out when it is switched on.

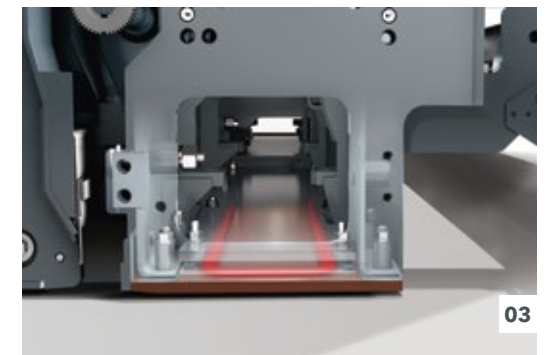

- 01** Locking bolts on both sides secure the screed in its transport position.
- 02** Screed plates are fitted as standard with heating elements which distribute the heat all over the plates.
- 03** When the screed is in the floating position, the Screed Assist feature can also be activated.

01 Screed Lock

02 Screed Heating

03 Screed Assist



03 Screed Assist

This button switches Screed Assist on (LED lights up) or off. Screed Assist pressure and balance can be set via the display. Screed Assist is active only when the screed is floating.

THE ERGOPLUS 3 SCREED CONSOLE

The screed is crucial for pavement quality. Therefore, easy and positive handling of all screed functions is of utmost importance for high-quality road construction.

With ErgoPlus 3, the screed operator has the process of paving at his fingertips. All functions are easily comprehensible and all controls are clearly arranged.

The screed console is designed in keeping with the conditions prevailing on the job site. Push-buttons are provided for the frequently used functions operated from the screed console. These are watertight and enclosed in palpably raised rings, so that they are identifiable blindfolded simply by touch even when wearing work gloves. Important paver and screed data can be called up and adjusted from the screed console, too.



01 The screed console is specially designed for night-time operation. To prevent operator errors, the buttons are backlit as soon as dusk falls or in darkness. What is more, the downward-angled high-power LED lighting gives the operator a perfect view of all processes associated with the end gate.

02 The screed width can be effortlessly adjusted by means of the "SmartWheel".



01 The display of the screed console

02 Ergonomic screed width control in two speeds

03 Crown adjustment at the press of a button

01 The display of the screed console

The screed console display allows the screed operator to control and monitor both the left and the right side of the screed. Machine-related parameters such as vibration speed or conveyor speed can be adjusted conveniently via the display panel of the screed console. The clear menu structure, combined with easily understandable, self-explanatory symbols neutral in language, makes operating the display panel both simple and safe.

02 Ergonomic screed width control in two speeds

The screed width can be effortlessly adjusted by means of the "SmartWheel". This is done in two speeds: slow, for precise control e.g. along an edge, or fast, for rapid extension or retraction of the screed.

03 Crown adjustment at the press of a button

The crown can be conveniently adjusted at the press of a button on the screed operator's console. When pressing the "plus" or "minus" keys, the set crown value is shown on a pop-up window. The conveyors and augers are adjusted accordingly.

NIVELLIERAUTOMATIK NIVELTRONIC PLUS

Niveltronic Plus, the System for Automatic Grade and Slope Control, is an in-house development by VÖGELE based on many years of experience in grade and slope control technology. Easy operation, precision and reliability are its hallmarks, ensuring perfect mastery of all grade and slope control jobs.

This fully integrated system is optimally adapted to the machine technology of the Premium Line pavers. All wiring and connections, for instance, are integrated into the tractor, effectively eliminating all risk of damage to these components.

VÖGELE naturally offer a particularly large and practical selection of sensors permitting versatile use of the Niveltronic Plus system. Whether for instance car parks, roundabouts or highways need to be built or rehabilitated, VÖGELE offer the right sensor for every job site situation.

Sensors can be changed quickly and easily, for Niveltronic Plus automatically detects which sensor is connected, thus simplifying the configuration process for the user.



01



02



03

- 01 The LED sighting crosses also fitted to the sensor provide continuous, clearly visible feedback to the screed operator indicating whether the actual values match the settings made.
- 02 A variety of sensor types are available for Niveltronic Plus, in keeping with the machine's extensive and varied range of applications. These sensors extend from a mechanical sensor to non-contacting sonic sensors.
- 03 The two-way split display provides the screed operator with access to both sides of the screed. The symbols provide information at all times including on the height of the tow point rams, the pre-set and actual values, and the pre-set sensitivity of the grade and slope control sensors.



VÖGELE > GOOD TO KNOW



Sensors available

Slope sensor

The slope sensor allows the transverse profile to be determined exactly and then paved accurately. The measuring range is +/- 10%.

Variable mechanical grade sensor

The variable mechanical grade sensor can be equipped with skis for referencing from the ground in 30 cm, 1 m and 2 m lengths.

Single-cell sonic sensor

The single-cell sonic sensor emits a sound cone and consequently copies references 1:1 without calculating an average. It can be used for referencing from the ground (Ground mode) or from a tensioned wire (Stringline mode).

Multi-cell sonic sensor

The multi-cell sonic sensor, with its four sensors, is highly versatile. By calculating an average, it can compensate for short irregularities in a reference.

Big MultiPlex Ski

The Big MultiPlex Ski compensates for extended undulations. Its 5 to 13 metre beam can be fitted with three multi-cell sonic sensors as standard - or with up to five if required.



01



02



03



04



05



06



07

THE ERGOPLUS 3 OPERATOR'S STAND

Improved efficiency, reliability and convenience

An ergonomic workstation is of key importance to enable a paver operator to concentrate fully for long periods of time, which is why VÖGELE relies on the paver operator's stand with ErgoPlus 3. The operator's ErgoPlus 3 stand provides plenty of storage space, is clearly arranged and meets stringent health and safety requirements.

Outstanding all-round visibility also increases safety. The operator can monitor everything from his workstation: material feed, material supply and head of mix. With its intelligent design, the ErgoPlus 3 system proves that innovative technology can be controlled ergonomically, efficiently, intuitively and conveniently.

01 The comfortable operator's stand

> The comfortable operator's stand gives an unobstructed view of all crucial areas on the paver such as material hopper, steering guide or screed. It allows the paver operator to closely monitor the paver's feed with mix and the process of paving.

02 Control console and seats can be moved for an optimum seated position

> The seats swinging out to the sides and an operator's stand of streamlined design provide maximum visibility of the auger tunnel, permitting the paver operator to keep an eye on the head of mix in front of the screed at all times.

> On the "Dash 3" machines, the paver operator's seat and console, as well as the screed consoles can now be adjusted even more easily to personal needs.

03 Hardtop gives excellent protection

> The modern hardtop made of glass fiber reinforced polymer material shelters the operator whether rain or shine.

04 A place for everything and everything in its place

> The operator's stand, with its streamlined design, is well organized, offering the paver operator a professional workplace. The operator's console can be protected by a shatter-proof cover to prevent willful damage.

05 Consistent service concept

> All "Dash 3" pavers have a consistent maintenance concept with identical service intervals.

06 Ergonomic screed console

> The height and position of the console are easily adjusted. The high-contrast color display can be read clearly from all angles.

07 Easy transport

> The machine can be prepared quickly and easily for transport on a low-bed trailer. Even the hardtop can be folded down to transport position using a manual hydraulic pump.

SCREEDS TO MEET ALL NEEDS

Several screed options are available for the SUPER 2003-3i, featuring different equipment with compacting systems. The paver can be combined with the VF 600, the VR 600 and the AB 600 Extending Screeds.

VÖGELE VF 600 screed, with unequal-width front-mounted extensions for multivariable width applications. Maximum paving width is 25 ft. and 6 in. (7.75 m) with bolt-on extensions.

VÖGELE VR 600 screed, with rear-mounted extensions for mainline applications. Maximum paving width is 24 ft. (7.3 m) with bolt-on extensions.

VÖGELE AB 600 screed, with rear-mounted extensions, achieves higher compaction thanks to vibration and tamper. The screed is particularly suited for placing cold RAP (Reclaimed Asphalt Pavement) for roadbase and polymer modified asphalt. Maximum paving width is 24 ft. 7 in. (7.5 m) with bolt-on extensions.



Electric screed heating

A consistent surface texture is achieved by uniform heating of the screed plates. With the engine running at minimum rpm, the time required for the screed to reach operating temperature is reduced substantially due to an intelligent generator management system.

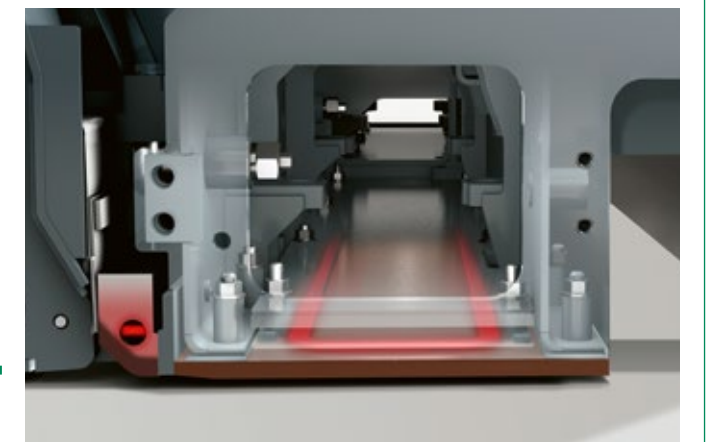

VF 600 EXTENDING SCREED WITH FRONT-MOUNTED EXTENSIONS

for multivariable width applications

Working at high paving speeds with varying paving widths requires a screed that can always be relied on to deliver precise results. The VF 600 Extending Screed from VÖGELE is just such a system. So it is the ideal tool for multivariable width applications.

Screed telescoping system

Robust, large-scale guidance system featuring high-precision operator control ensures excellent screed stability, resulting in top-quality paving.

VÖGELE screeds are renowned in the industry worldwide for their high precision and robustness. The VF 600 screed is designed specifically for the North American market, and provide one key feature above all: speed. The screed consistently meets the demands of paving at high speed and across widely varying pave widths. The telescopic guidance system, for example, enables very smooth and precise width adjustment.

The L-shaped frame also provides high rigidity in longitudinal and transverse directions, while allowing controlled torsion. This means the screeds can be adapted very well to a wide variety of paving situations, including when installing speed bumps. The hydraulic bolt-on extensions also enable the paving team to vary the working width quickly and precisely.

- 01 **Crown**
Crowns of -2% to +5% are easy to set.
- 02 **Crown Control**
The continuous screed plate of the main screed paves precise crowns.
- 03 **Screed telescoping system**
The sturdy guide rods can be extended at two speeds.
- 04 **Slope**
Slopes of up to 10 % are possible and there is no need to readjust the road profile at any time while paving.
- 05 **Berm**
The optional berm is available in three different widths: 12, 18, or 24 inches.



VF 600 EXTENDING SCREED

The VF 600 Extending Screed is equipped with extending units mounted in front of the main screed and was developed especially for the VÖGELE 10-foot pavers. This screed is eminently suitable for the requirements prevailing in road construction in North America and Australia.

The VF 600 is ideal for applications which require a variable paving width, such as car parks with islands and light masts, roads for residents only, urban roads with manhole covers, gas or water connections, junctions on highways or work on country roads, i.e. jobs which involve paving around obstacles.



VF 600

Paving widths

- > Infinitely variable range from 10 ft. to 19 ft. 6 in. (3.05 m to 5.95 m)
- > Maximum paving width with bolt-on extensions 25 ft. 6 in. (7.75 m)

Compacting system

- > VF 600 V with vibration

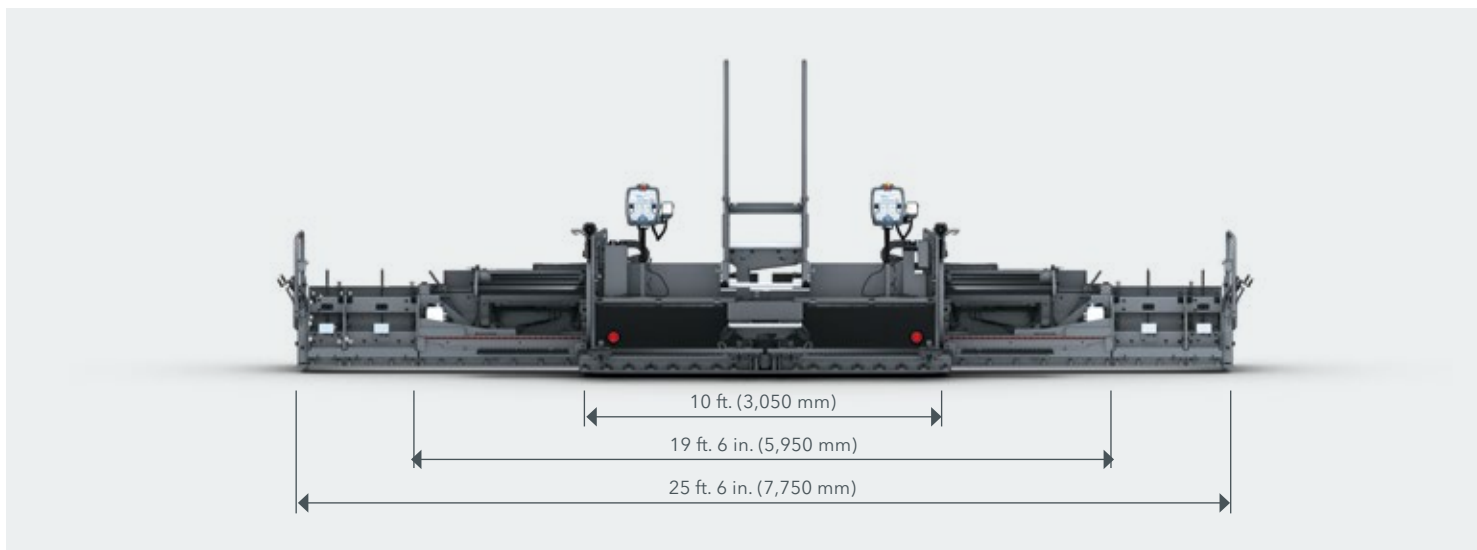

SCREEDS WITH REAR-MOUNTED EXTENSIONS

for almost unlimited applications

When paving across large widths, absolute accuracy of line and levels is a crucial criterion for prime-quality results, regardless of the paving width and layer thickness involved. The VR 600 and

the AB 600 Extending Screeds boasts impressive abilities in their respect and are therefore the perfect choice for medium and large-scale road construction projects.

Uniform screed heating
for uniform surface courses

Much shorter preheating time
thanks to intelligent generator management

Alternating mode for screed heating
alternately powering one half of the screed heating system

Hydraulic crown adjustment
at the press of a button on the screed operator's console

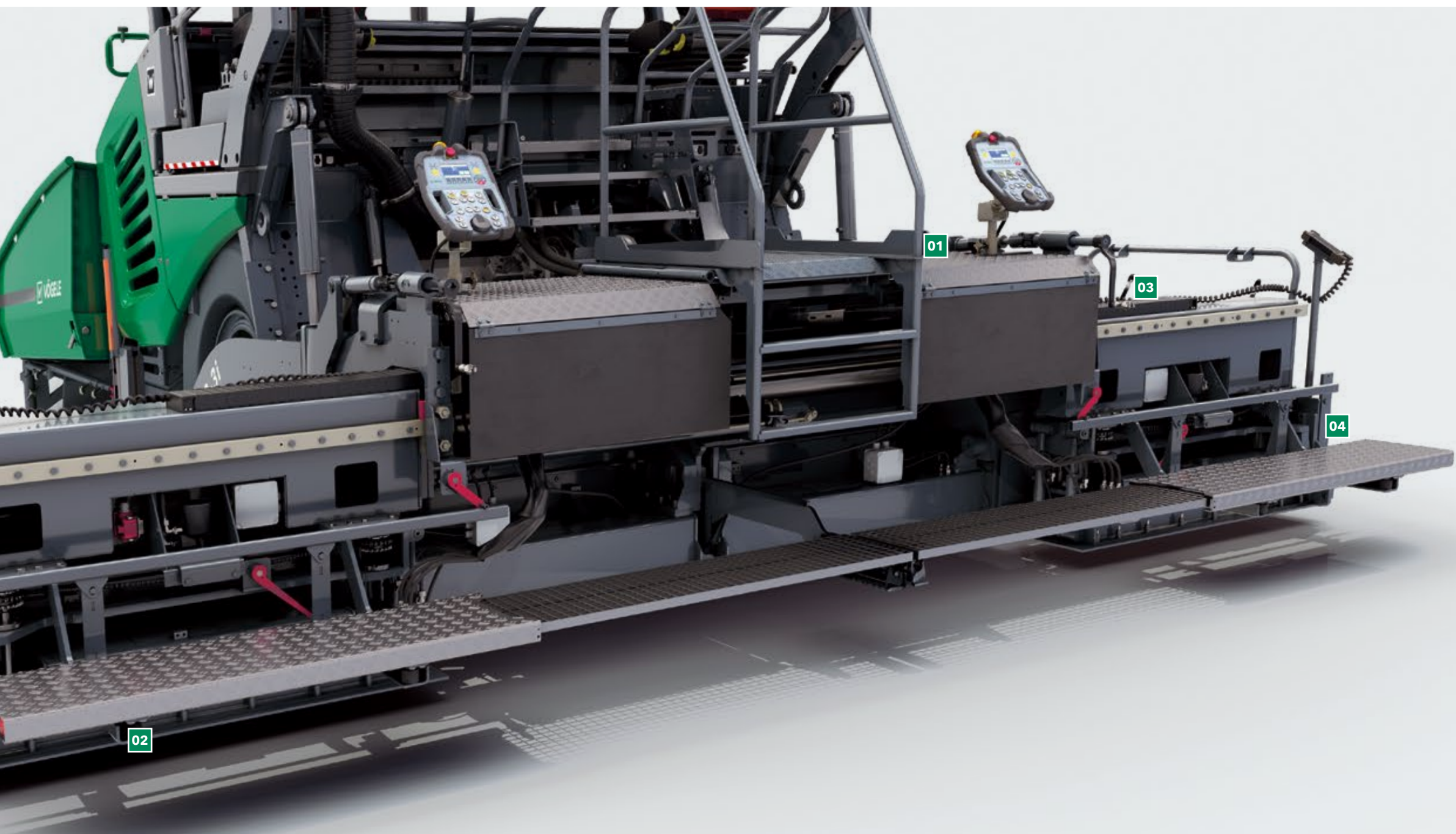

01 Safe, convenient screed step

> The walkway and convenient central step on the screed allow safe, convenient access to the paver operator's platform.

02 Outstanding paving characteristics

> Optimized geometry of the tamper bar and the screed plates achieves particularly stable floating behaviour of the screed.

03 Single-tube telescoping system

> Amply dimensioned, high-precision, stable single-tube telescoping system gives the screed system a high degree of stability and provides the basis for good paving results.
> Even with the screed set to its maximum width, the telescoping tubes are extended by no more than half, thus ensuring superb screed rigidity with zero flexing.

04 Innovative screed heating

> In order to optimise compaction performance and to produce a smooth surface structure, all compacting elements are heated across full screed width. Screed plates are fitted as standard with heating elements which distribute heat throughout the plates. The plates are thoroughly insulated on top so that 100% of the heat is directed to where it is needed: the area of contact with the mix. Tamper bar and pressure bars are fitted with heating rods for quick and uniform heating from the inside. Sophisticated control technology is installed to allow automated management of screed heating.

VR 600 EXTENDING SCREED

The VR 600 Extending Screed is tailored to meet the requirements of the North American and Australian markets, but the hydraulic extensions are located behind the basic screed, as they are on the extending screeds. A special feature is the structure of the hydraulic extensions: this supports the construction of pavement

profiles with a slope of up to 10% towards the edge of the road. In combination with the 10-foot SUPER 2000-3i paver, the screed's sturdy design makes it especially suitable for paving highways up to 28 ft. 3 in. (8.6 m) wide with high precision and at high pave speeds.

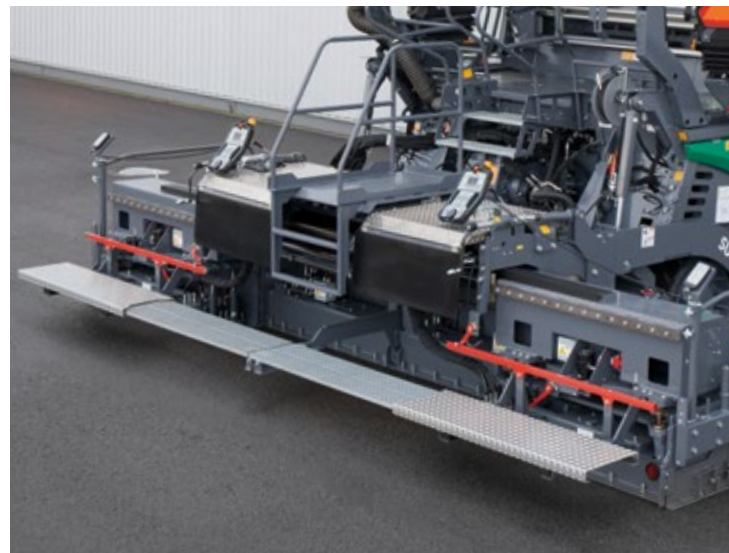

VR 600

Paving widths

- > Infinitely variable range from 10 ft. to 19 ft. 8 in. (3.05 m to 6 m)
- > Maximum paving width with bolt-on extensions 24 ft. (7.3 m)

Compacting system

- > VR 600 V with vibration

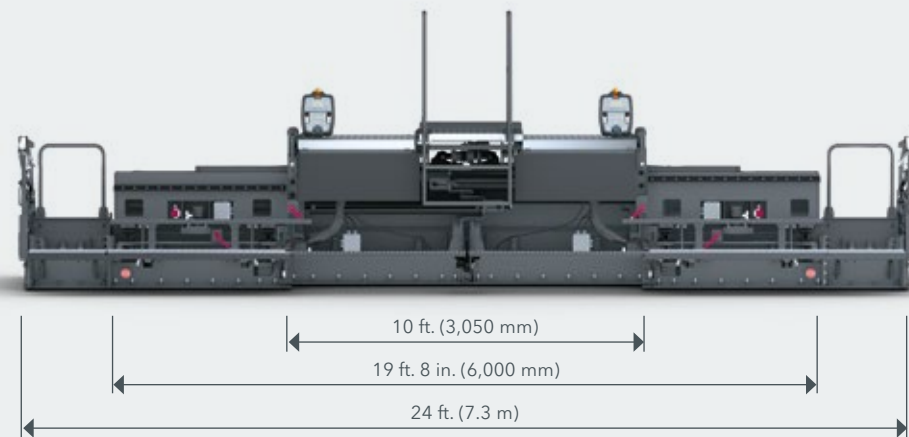

AB 600 EXTENDING SCREED

The AB 600 has a basic width of 9 ft.10 in. (3 m). Equipped with the rugged single-tube telescoping system, its screed width is infinitely variable up to 19 ft. 8 in. (6 m). With the addition of

bolt-on extensions, lanes as wide as 24 ft. 7 in. (7.5 m) can be paved without joints. This consequently makes the screed ideal for use with the SUPER 2003-3i Wheeled Paver.



AB 600

Paving widths

- > Infinitely variable range from 9 ft.10 in. to 19 ft. 8 in. (3 m to 6 m)
- > Maximum paving width with bolt-on extensions 24 ft. 7 in. (7.5 m)

Compacting systems

- > AB 600 TV with tamper and vibration

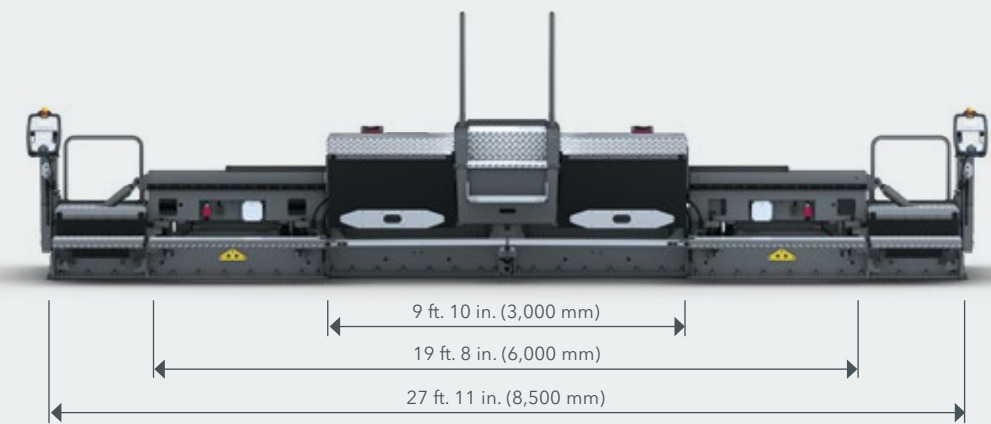

ALL THE FACTS AT A GLANCE

SUPER 2003-3i Wheeled Paver



TECHNICAL DATA

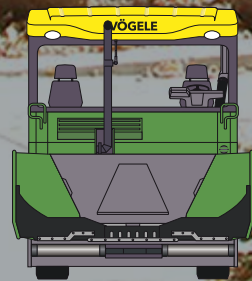

SUPER 2003-3i

- > Maximum paving width: 25 ft. 6 in. (7.75 m)
- > Maximum laydown rate: 1,540 tons/h (1,400 tonnes/h)
- > Layer thickness: up to 12 in. (30 cm)
- > Transport width: 10 ft. (3.05 m)

WIRTGEN GROUP CUSTOMER SUPPORT

Service you can rely on.

You can have confidence in reliable, swift support from us during the entire life cycle of your machine. Our wide range of services is ready with the right solution to every challenge you face.



Service

We keep our service promise with swift, straightforward assistance - on the job site or at our professional workshops. Our service team is trained to a professional standard and dedicated tools ensure that repair, care and maintenance tasks are completed quickly. We can support you with customised service agreements on request.

> www.wirtgen-group.com/service



Spare Parts

WIRTGEN GROUP original parts and accessories assure the long-term reliability and availability of your machines. Our experts will also be pleased to advise you about optimised wear part solutions to suit your application. Our parts are available all over the world at all times and are easy to order.

> parts.wirtgen-group.com



Training

The WIRTGEN GROUP brands are specialists in their field with decades of experience in applications; our customers benefit from this expertise.

In our WIRTGEN GROUP training courses, we are delighted to pass our knowledge on to you, customised to suit both operators and servicing staff.

> www.wirtgen-group.com/training



Telematics solutions

At the WIRTGEN GROUP, construction machinery involving leading-edge technology goes hand in hand with sophisticated telematics solutions. Intelligent monitoring systems such as WITOS or JD Link* not only make it easier for you to plan the maintenance of your machines, they also increase productivity and efficiency.

> www.wirtgen-group.com/telematics

* Neither WITOS nor JD Link are currently available in all countries.
Please contact the subsidiary or dealer responsible for you for more information about this.

**Wirtgen America, Inc.**

6030 Dana Way
Antioch, TN 37013
USA

T: +1 615 501-0600

F: +1 615 501-0691

M: info.america@wirtgen-group.com

 www.wirtgen-group.com/america



For more information scan the code.