

Tracked Paver

# SUPER 1000(i)

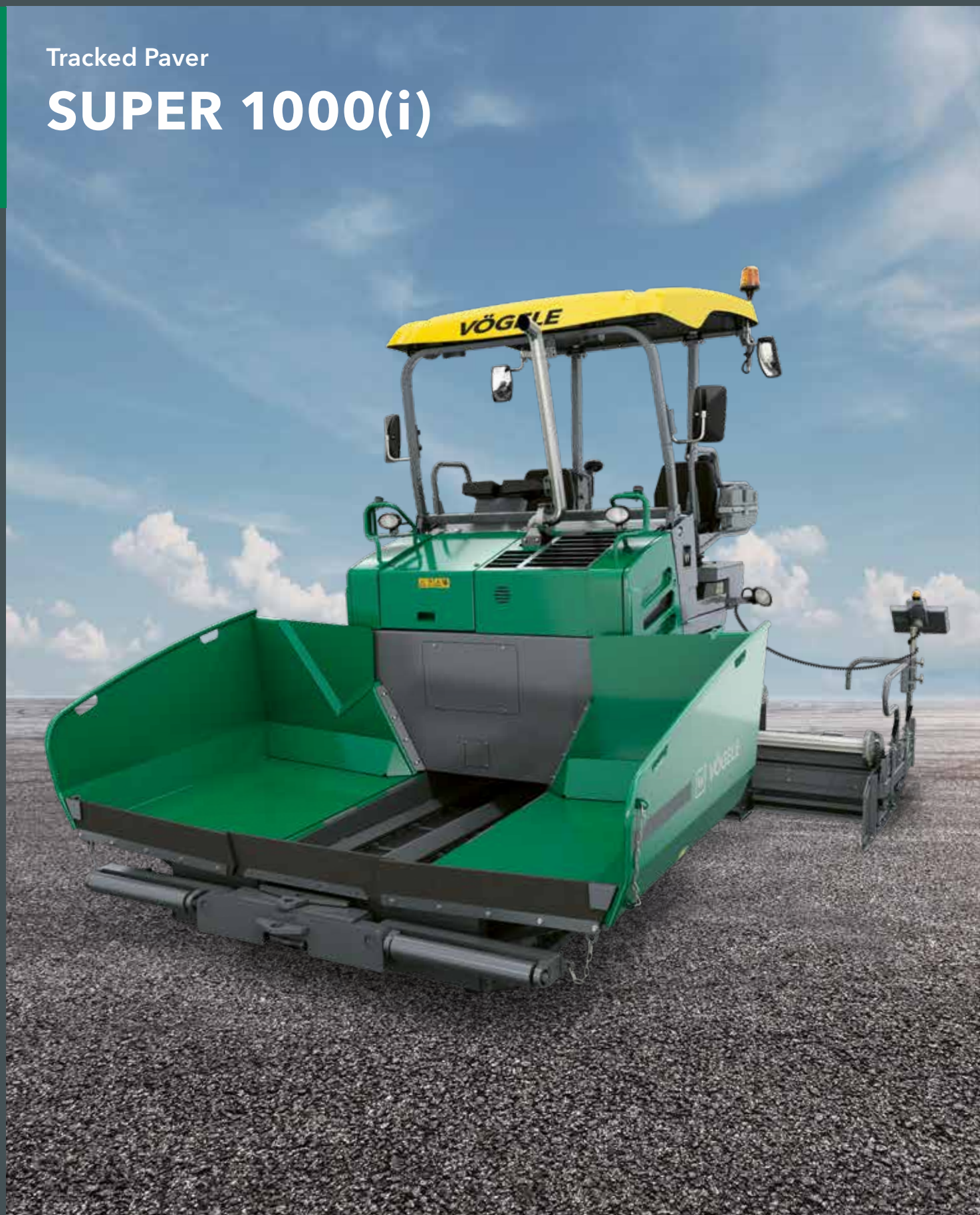



# PERFECT IN ALL CLASSES

The right paver for every job

VÖGELE's seamless product range is considered unique in the industry. Whether a service road or a motorway, an airfield or a race track, a new construction or a rehabilitation job, thick or thin, hot or cold – customers will find the right machine in our paver range for every paving task.

## VÖGELE PRODUCT RANGE

### MINI CLASS

- > Maximum pave width 3.5 m
- > Maximum laydown rate 300 t/h

### COMPACT CLASS

- > Maximum pave width 5 m
- > Maximum laydown rate 350 t/h

### UNIVERSAL CLASS

- > Maximum pave width 10 m
- > Maximum laydown rate 700 t/h

### HIGHWAY CLASS

- > Maximum pave width 18 m
- > Maximum laydown rate 1800 t/h

### SPECIAL CLASS

- > SprayJet
- > InLine Pave

### POWERFEEDER

- > MT 3000-3(i) Standard
- > MT 3000-3(i) Offset



# HIGHLIGHT OVERVIEW

Perfectly equipped



## DRIVE

### 01 Drive concept

> Powerful and economical drive concept with a state-of-the-art diesel engine.



### 02 Crawler tracks

> Long crawler tracks with controlled advance drives for optimum traction.

## MATERIAL MANAGEMENT

### 03 Optimum mix feed

> Large material hopper with a capacity of 10 tonnes ensures optimum feeding with mix.

## OPERATION

### 04 ErgoBasic operating system

> Innovative, easy-to-grasp ErgoBasic operating concept for simple handling.

### 05 Niveltronic Basic System for Automated Grade and Slope Control

> Easy-to-operate system for automated grade and slope control.

## VERSATILITY

### 06 Wide range of applications

> Tracked paver with a wide range of applications and pave widths up to 3.9 m.

### 07 Extending Screed

> Can be combined with the AB 340 Extending Screed in the V and TV versions.



VÖGELE SUSTAINABILITY is our name for innovative technologies and solutions which contribute to the sustainability objectives of the WIRTGEN GROUP.





01



02



03



04



05



06

## POWERFUL, ECONOMICAL AND QUIET

The SUPER 1000(i) is a particularly compact paver that is cost-efficient in every respect.

As a representative of the Classic Line, the SUPER 1000(i) features a range of functions essential for paving teams to operate successfully.

VÖGELE's Classic Line machines are equipped with the ErgoBasic operating system. It was developed on the basis of the proven ErgoPlus 3 operating system, but tailored specifically to the requirements of Classic Line machine users. As with ErgoPlus 3, the design of the paver operator's ErgoBasic console is so clear that all functions can be grasped quickly and operated securely.

The SUPER 1000(i) can be combined with the AB 340 Extending Screed with vibrators (V version) or with tamper and vibrators (TV version). Thanks to its range of pave widths extending from 0.75 m to 3.9 m, the paver is ideally suited to the construction or rehabilitation of combined footpaths and cycle paths, farm tracks, minor roads and small areas.

01 ErgoBasic operating system with numerous convenient and automatic functions.  
02 Tracked paver with a large range of applications.  
03 The slim design and compact overall length of this paver make it very easy to work and to manoeuvre on tight job sites.

04 The paver operator's platform ensures maximum visibility.  
05 Large material hopper for optimum feeding with mix.  
06 AB 340 Extending Screed ensures a perfect paving result.





# COMPACT DIMENSIONS FOR PAVING IN VERY TIGHT SPACES

Small size, high efficiency: be it extremely confined job sites outside of town or winding inner-city alleyways, the highly manoeuvrable VÖGELE Compact Class pavers can negotiate tight spots with ease while delivering top performances.

The slim paver design, with no protruding edges and a compact overall length, makes it very easy to work and manoeuvre on tight job sites.

With their combination of compact dimensions and top performance, road pavers in the VÖGELE Compact Class can handle a wide variety of applications. Whether it is a combined footpath and cycle path, a farm track or minor roads and small areas, the SUPER 1000(i) is more than up to the task, thanks to its wide range of pave widths from 0.75 m to 3.9 m and its innovative drive concept.



The push-rollers automatically fold up together with the hopper sides.

**Clearance width of 1.85 m**  
allows the machine to access even narrow alleys

**Slim paver design**  
and compact total length



For transport, the hardtop, made of a glass fibre-reinforced polymer material, and the exhaust pipe can be folded down

just a few swift moves, readying the paver for transport quickly and easily.





# FULL POWER, INTELLIGENT TECHNOLOGY

High output with low consumption

**Three main components form the power unit of the SUPER 1000(i): the large cooler assembly, an advanced, liquid-cooled diesel engine and a splitter gearbox flanged directly to the engine.**

The driving force behind this VÖGELE powerhouse is a powerful diesel engine. The 4-cylinder engine delivers 55,4 kW at 2,000 rpm, though fuel-saving ECO mode is sufficient for many applications. Moreover, the machine operates particularly quietly when running at just 1,600 rpm.

A large cooler assembly ensures that the power unit always delivers its full output. With innovative air routing and a variable-speed fan, temperatures are continuously maintained within the optimum range, significantly extending the service life of both the diesel engine and the hydraulic oil.

Another advantage is that the machine can be operated without difficulty in all climatic regions around the world.

All hydraulic consumers are directly supplied with hydraulic oil via the splitter gearbox. Hydraulic pumps and valves are centrally located, making them optimally accessible for servicing.



- = Hydraulic oil cooler
- = Fuel cooler
- = Coolant cooler
- = Charge air cooler

<b>55.4 kW</b> diesel engine output	<b>ECO mode at 1,600 rpm</b> reduces operating costs	<b>Intelligent generator management</b> adapts output to suit pave width
--	---	---



## VÖGELE > GOOD TO KNOW

### Exhaust emissions aftertreatment on "i" machines

On the engine of the SUPER 1000i, exhaust emissions aftertreatment is provided by the diesel oxidation catalyst (DOC) and a diesel particulate filter (DPF), so engines of the "i" machines satisfy the strict requirements of European exhaust emissions standard Stage V.

For less regulated markets, a variant without exhaust emissions aftertreatment is available. This corresponds to European exhaust emissions standard stage 3a and US standard EPA Tier 3.



# EFFICIENT TRANSMISSION OF ENGINE POWER

Thanks to high-quality separate hydraulic drives, our pavers operate extremely cost-efficiently at a high performance level. With its powerful crawler tracks, the SUPER 1000(i) has no problem pushing feed vehicles or working at a wide pave width on a soft base. In terms of traction, too, the VÖGELE drive concept for tracked pavers leaves nothing to be desired.

The hydraulic systems for the traction drive, conveyors and augers as well as the compacting systems all operate in separate closed circuits for maximum efficiency.

- > Long crawler tracks deliver maximum traction thanks to their large footprint. This ensures a constant forward speed even when operating on difficult terrain.
- > Positive tracking when moving straight and accurate cornering due to electronically controlled separate drives provided for both crawler tracks.
- > Powerful separate drives, installed in the sprockets of the crawler tracks, translate engine output into pave speed with no loss of power.

**Powerful separate drives**  
fitted into the sprockets

**Positive tracking when moving straight ahead**  
with electronic control of each crawler track





# PERFECT MATERIAL MANAGEMENT FOR PERFECT PAVING QUALITY

**A continuous flow of mix is key to ensuring uninterrupted and high-quality paving. That is why we attach such importance to professional material management when designing our pavers.**

All our development efforts focus on simple operation and the best possible overview for the paving team.

Should material feeding become difficult on confined job sites, the large volume of the SUPER 1000(i)'s material hopper guarantees that the screed can still be optimally supplied with mix. Separately folding hydraulic hopper sides ensure smooth feeding with mix, even when paving across asymmetrical widths and along boundaries.

The large material hopper has a capacity of 10 t so that a sufficient quantity of mix is available for paving at all times, even in situations where feeding is difficult, such as when paving under bridges.

Separately folding hydraulic hopper sides for smooth feeding with mix, paving along boundaries and a targeted mix supply even when paving across asymmetrical widths. Oscillating push-rollers for convenient and shock-free docking also of large feed vehicles.



**Large material hopper**  
with a capacity of 10 tonnes

**Deep and wide hopper sides**  
for especially straight forward material feed

**Oscillating push-rollers**  
for convenient docking without jolting

**01** The amply dimensioned conveyor tunnel and powerful, separate hydraulic drives for conveyors and augers support laydown rates of up to 270 t/h, which are extraordinarily high for a paver in this class. Separate drives and controls are installed for each conveyor and auger. When operating in Automatic mode, conveyors and augers are subject to continual monitoring. Proportional control provides for a constant head of mix in front of the screed.



The conveyance and even spreading of mix in front of the screed are optimal thanks to the large conveyor tunnel, proportional control of conveyors and powerful augers.

What is more, the height-adjustable augers and folding limiting plates for the auger tunnel allow the paver to be repositioned without a need for conversion, a benefit that saves time and money.

## VÖGELE > GOOD TO KNOW

### Adjustable auger height

The height of the augers is infinitely variable by 13 cm for uniform spreading of mix across the entire pave width.







## ERGOBASIC OPERATING CONCEPT

Full control for the machine operator

The ErgoBasic operating concept was developed on the basis of the proven ErgoPlus operating system which is installed in our Premium Line pavers, but was tailored specifically to the needs and requirements of VÖGELE Classic Line users.

The goal was to develop an operating system that can be operated just as quickly, accurately and intuitively as the ErgoPlus 3 system on the "Dash 3" machines. This makes VÖGELE the only manufacturer to offer a standardized operating concept for all paver classes.





# ERGOBASIC PAVER OPERATOR'S CONSOLE

Everything at a glance

The functions are arranged in a clear, logical and practical layout that has clearly been inspired by the ErgoPlus operating console. The type of controls and the symbols used are all in line with those on an ErgoPlus console. Given the limited number of functions, there is no need for a display. The status of all settings is indicated as a

percentage on LED strips immediately next to the relevant functions.

Additional LEDs indicate the set speeds of the augers and the compacting systems as well as the fill level of the diesel tank.



## Safe operation at night

Glare-free backlighting comes on automatically as darkness sets in so that the paver operator can continue working safely on night-time jobs.

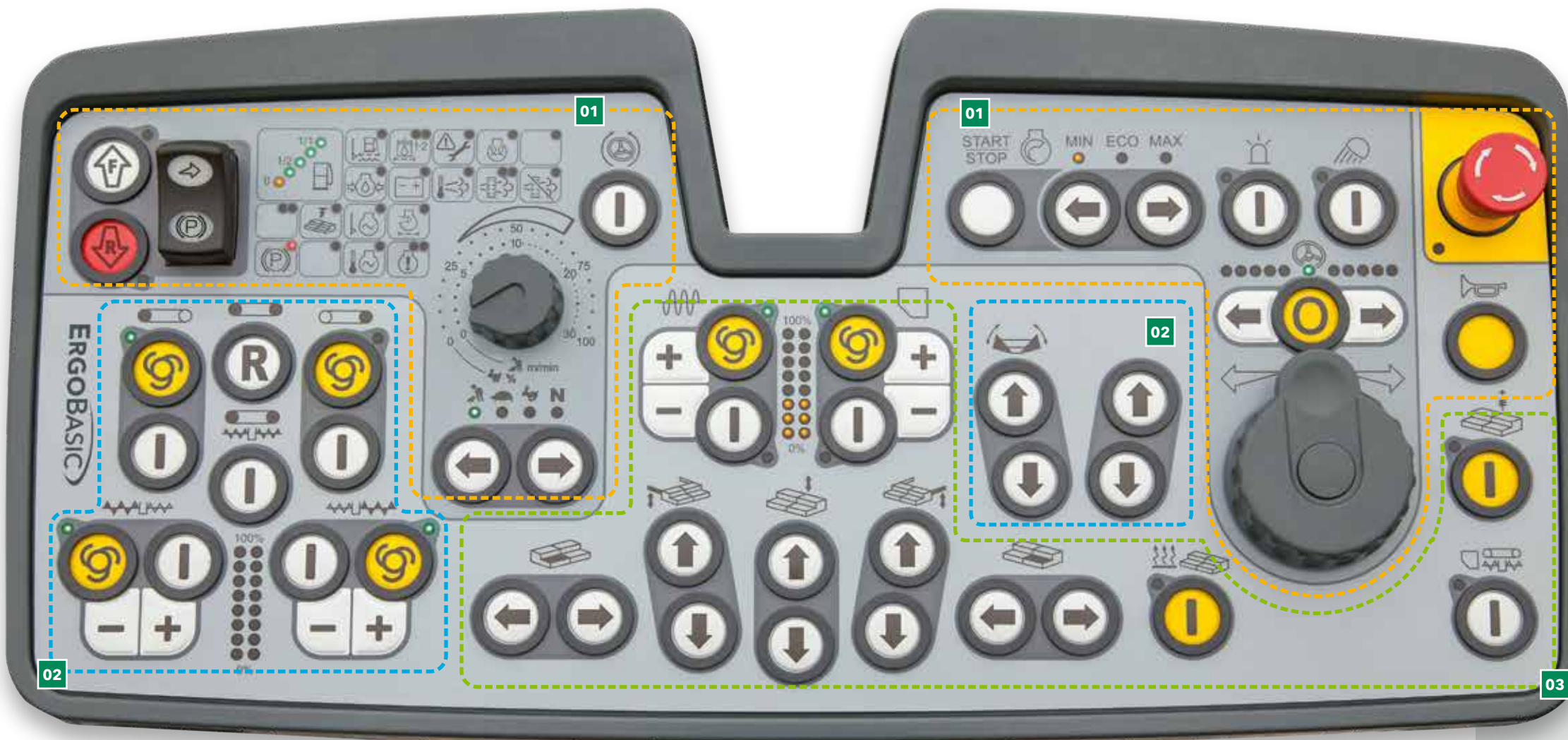

### 01 Drive and status display function group

All the functions for driving the paver are collected together here. The status displays also provide an overview of paver status.

### 02 Material handling function group

The material handling function group includes operation of the hopper sides and for conveyor and auger.

### 03 Screed function group

This function group contains all the screed functions, including the settings for tamper and vibrators and adjustment of screed width and pitch.



# DRIVE AND STATUS DISPLAYS

## Function group 1

### 01 Choice of operating modes

At the touch of a button, the paver switches to Pave, Positioning, Job Site and Neutral modes. An LED indicates which mode is selected. When Pave mode is exited, the memory function saves all the values last set. After the paver moves on the job site, the previously used paving parameters are thus instantly restored.

### 02 Steering at a preselected steering angle

The machine is steered by means of a rotary controller which enables the paver operator to manoeuvre the machine precisely even in the tightest spots. For long curves with a constant radius, the desired steering angle can be preselected using arrow keys. The paver automatically stays on the set track until the function is deactivated, allowing the paver operator to monitor the paving process undisturbed.



**01** At the touch of a button, the paver switches between Pave, Positioning, Job Site and Neutral modes.

**02** The machine is steered by a rotary controller for simple, precise manoeuvring.



### 03 Function and status indicators

The function and status indicators mean that the operator always has full control over his machine, even without a display. He can, for instance, read the fill level of the fuel tank directly and identify whether there are any functional faults.

### 04 Choice of engine speed ranges

There are three speed ranges for the diesel engine: MIN, ECO and MAX. The desired range can be set easily using the arrow keys. Many construction projects can be completed at ECO rpm. The lower engine speed reduces noise emissions considerably and saves fuel.



# MATERIAL MANAGEMENT

## Module 2

### 01 Speed of the augers

In automatic mode, the maximum speed of the augers can be adapted to pave width separately for the left and right using the plus and minus keys. The set value is displayed as a percentage on the LED strip.

### 02 Reverse conveyor movement

In order to prevent soiling as a result of mix dropping off the conveyor when the paver is repositioned on the job site, conveyor movement can be reversed at the touch of a button - at the end of a section, for example. Reverse movement takes place for a short time only and stops automatically.



The conveyor can be reversed at the touch of a button. Return transport of the mix is automatically stopped. The conveyor can be switched to the no-load function just as quickly.



### 03 Automatic functions for material handling/distribution

These functions ensure that enough mix for paving is automatically conveyed and distributed in front of the screed. A material sensor defines the height of the head of mix and the automatic system ensures that this remains constant. The function is only active during paving - if the paver stops, so does material handling.



# SCREED FUNCTIONS

## Module 3

### 01 Precompaction performance

The speeds of the compacting systems can be set directly on the operator's console. The LED strips from 0 to 100% indicate the set speeds for the tamper and vibrators, allowing them to be adjusted immediately when required.

### 02 Screed Assist (option)

This is used to switch Screed Assist on and off. Screed Assist is only active when the screed is floating.



01 Compacting effort  
02 Screed Assist (option)  
03 Screed settings



### 03 Screed settings

All key screed settings can be made from the paver operator's console. As a result, the screed can be raised or lowered, each of its two sides extended or retracted or the height of the tow point rams adjusted from here, giving the paver operator access to the screed at all times.

### 04 Idling function

Idling function allows the machine to warm up or conveyors, augers and tampers to be cleaned.

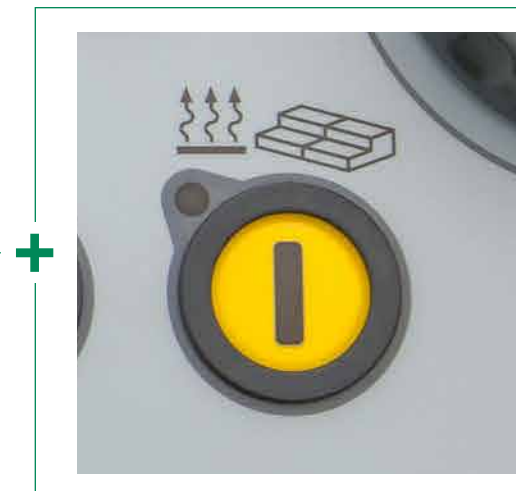

### Screed Heating

In order to optimise compaction and produce a smooth surface texture, all compacting elements are heated across full screed width. A simple touch of a button is all it takes to switch screed heating on or off. To ensure the screed heating system is working properly, an automatic function check is carried out when it is switched on.



# THE ERGOBASIC REMOTE CONTROL UNIT FOR THE SCREED

Simple, reliable handling of all screed functions is a key factor in high-quality asphalt paving, which is why an ErgoBasic screed remote control unit was developed especially for the operating system of these compact pavers. Its keypad is arranged logically to suit functional processes and its robust design is well able to withstand harsh job site conditions.

Operation is easy to understand and can thus be learned intuitively in a very short space of time, not least because the symbols used were adopted from the proven ErgoPlus operating concept.

The ErgoBasic screed operator's console allows all the functions relevant to paving to be adjusted quickly and easily. These also include direct access to the material handling systems and the sonic sensor for the auger.



### 01 Auger output

In automatic mode, the maximum speed of the augers can be adapted to pave width separately using the plus and minus keys. The set value is displayed as a percentage on the LED strip.



### 02 Screed Float on/off

The screed can be made to float at the touch of a button.



### 03 Screed width control

The screed width on one side can be adjusted at any time at the push of a button.



01 Auger, automatic/manual/reverse

02 Screed floating on/off

03 Screed width control, one side

04 Adjustment of screed tow point ram

There is a remote control unit for each side of the screed. The magnetic brackets and connection by means of a coiled cable give the operator a large range of operation, so that he can always operate the screed from the best possible position; this is of particular importance when working in confined job site conditions.

Shown in original size



# NIVELTRONIC BASIC

**VÖGELE has also developed a System for Automated Grade and Slope Control to match the ErgoBasic operating system: Niveltronic Basic. It is completely integrated in the machine control system and therefore perfectly adapted to the paver model concerned.**

An outstanding aspect of Niveltronic Basic is its particularly simple and intuitive handling, a feature which makes it easy even for less experienced operators to learn to use the system correctly. This creates ideal conditions for the compact pavers to work true to line and level on any terrain.

Each side of the screed is operated by a separate compact and highly robust Niveltronic Basic remote control unit. These units are easily removed from their magnetic brackets, giving the operator a large range of operation, so that he can always adopt the optimum position for every paving situation.



- 01** The LED sighting crosses fitted to the sensor provide continuous, clearly visible feedback to the screed operator indicating whether actual values match the settings made.
- 02** A variety of sensor types is available for Niveltronic Basic to suit the variety of applications for the paver. The sensors range from mechanical to non-contacting sonic sensors.
- 03** The pre-set and actual values for the grade and slope control sensor can be read off the display of the Niveltronic Basic control console.



- 01** Deviation from specified values
- 02** Setting: sensor sensitivity
- 03** Selecting: kind of reference (ground, tensioned wire, transverse slope)
- 04** Quick set-up
- 05** Sensor calibration

## VÖGELE > GOOD TO KNOW

### Sensors available

#### Slope sensor

The slope sensor allows the transverse profile to be determined exactly and then paved accurately. The measuring range is +/- 10%.

#### Variable mechanical grade sensor

The variable mechanical grade sensor can be equipped with skis for referencing from the ground in 30 cm, 1 m and 2 m lengths.

#### Single-cell sonic sensor

The single-cell sonic sensor emits a sound cone and consequently copies references 1:1 without calculating an average. It can be used for referencing from the ground (Ground mode) or from a tensioned wire (Stringline mode).

#### Multi-cell sonic sensor

The multi-cell sonic sensor, with its four sensors, is highly versatile. By calculating an average, it can compensate for short irregularities in a reference.





## OPERATOR'S ERGOBASIC PLATFORM

Improved efficiency, reliability and convenience

The ErgoBasic paver operator's platform makes it perfectly simple for the paver operator to remain in his seat and monitor the paver as it is fed with material.

### 01 Comfortable paver operator's platform

> The comfortable paver operator's platform gives an unobstructed view of all crucial areas on the paver such as material hopper, steering guide or screed. The paver operator is thus ideally positioned to monitor the material feeding process right from his seat.

### 02 Working comfortably

> The operating console can be shifted across the entire working width so that operators can work comfortably and in an ergonomic position on either side of the machine.

### 03 A place for everything and everything in its place

> The paver operator's platform is streamlined and well organized, offering the paver operator a professional workplace. The paver operator's console can be protected by a shatter-proof cover to prevent wilful damage.

### 04 Hardtop provides excellent protection

> The modern hardtop, made of a glass fibre-reinforced polymer material, protects the operator. It can easily be collapsed to quickly prepare the paver for transport.

### 05 Safe and convenient step

> The walkway and convenient central step on the screed ensure safe and convenient access to the operator's platform.

### 06 Safe and simple operation of all screed functions

> All paving-related functions can be set quickly and easily on the ErgoBasic remote control unit for the screed.



# AB 340 EXTENDING SCREED

The AB 340 Extending Screed is optionally available for the SUPER 1000(i) with vibrators only (V version) or with tamper and vibrators (TV version). With this screed, rehabilitation jobs can be carried out very quickly and easily without ever compromising on quality.

Another typical VÖGELE feature found in the AB 340 Extending Screed is the powerful electric heating system. The modern screed heating system provides for quick and uniform heating to operating temperature, essential for a smooth surface texture. Excellent insulation of the screed plates reduces loss of heat to a minimum. It takes only a short time to heat the screed, even with the engine running at minimum rpm.

In automatic operation, the screed is heated in alternating mode, which means that only one half is heated at any one time, thus sparing the engine and saving fuel.



## Innovative screed heating

In order to optimize compaction performance and to produce a smooth surface structure, all compacting elements are heated across full screed width. Screed plates are fitted as standard with heating elements which distribute heat throughout the plates. The plates are thoroughly insulated on top so that 100% of the heat is directed to where it is needed: the area of contact with the mix. The tamper bar is fitted with heating rods for quick and uniform heating from the inside.

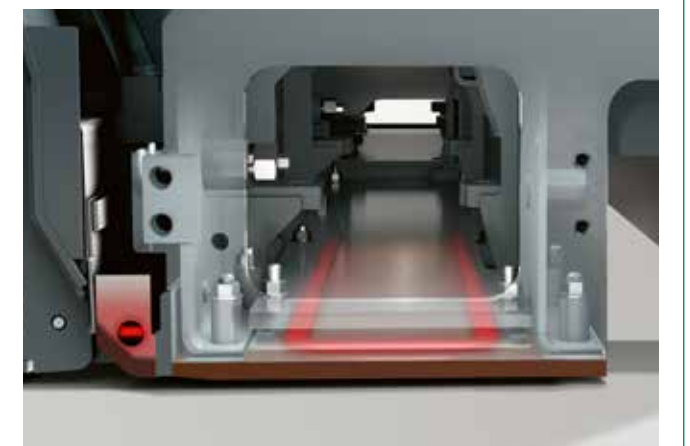





### AB 340

#### Pave widths

- > Infinitely variable range from 1.8 m to 3.4 m
- > Maximum pave width with bolt-on extensions: > 3.9 m (2 x 25 cm)
- > Minimum pave width of 0.75 m with the system for pave width reduction

#### Compacting systems

- > AB 340 V Extending Screed with vibrators
- > AB 340 TV Extending Screed with tamper and vibrators



Extended to maximum pave width

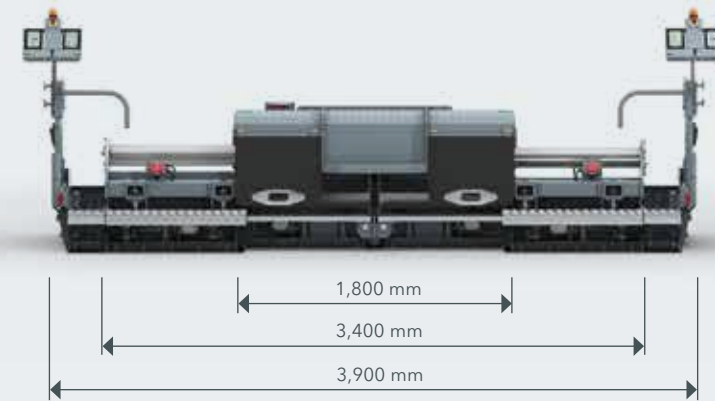

Easy transport with 25 cm bolt-on extensions

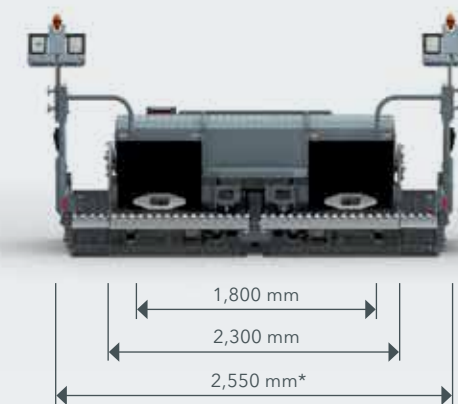

\*Even with bolt-on extensions and side plates fitted, the transport dimensions do not exceed 2.55 m.



# ALL THE FACTS AT A GLANCE

SUPER 1000(i) Tracked Paver



## TECHNICAL DATA

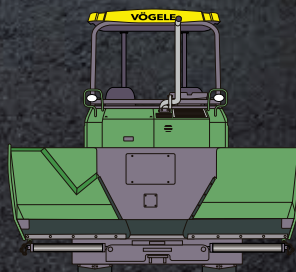
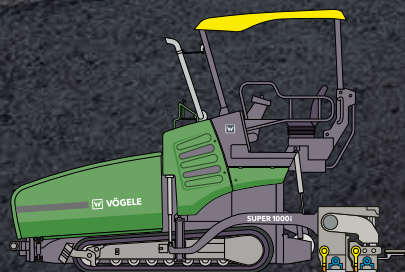

### SUPER 1000(i)

- > Maximum pave width: 3.9 m
- > Maximum laydown rate: 270 t/h
- > Layer thickness: max. 15 cm
- > Transport width: 1.85 m



# WIRTGEN GROUP CUSTOMER SUPPORT

Service you can rely on.

You can have confidence in reliable, swift support from us during the entire life cycle of your machine. Our wide range of services is ready with the right solution to every challenge you face.



## Service

We keep our service promise with swift, straightforward assistance - on the job site or at our professional workshops. Our service team is trained to a professional standard and dedicated tools ensure that repair, care and maintenance tasks are completed quickly. We can support you with customised service agreements on request.

> [www.wirtgen-group.com/service](http://www.wirtgen-group.com/service)



## Spare Parts

WIRTGEN GROUP original parts and accessories assure the long-term reliability and availability of your machines. Our experts will also be pleased to advise you about optimised wear part solutions to suit your application. Our parts are available all over the world at all times and are easy to order.

> [parts.wirtgen-group.com](http://parts.wirtgen-group.com)



## Training

The WIRTGEN GROUP brands are specialists in their field with decades of experience in applications; our customers benefit from this expertise. In our WIRTGEN GROUP training courses, we are delighted to pass our knowledge on to you, customised to suit both operators and servicing staff.

> [www.wirtgen-group.com/training](http://www.wirtgen-group.com/training)



## Telematics solutions

Construction machines with leading technology and perfected telematics solutions work hand-in-hand in the WIRTGEN GROUP. The Operations Center\* - the digital platform for process, machine and service optimisation - enables you to not only simplify maintenance planning for your machines, but also to increase your productivity and cost-effectiveness.

> [www.wirtgen-group.com/telematics](http://www.wirtgen-group.com/telematics)

\*The John Deere Operations Center™ (formerly WITOS) is currently not available in all countries. Please consult your responsible subsidiary or dealer if you have any questions.





## JOSEPH VÖGELE AG

Joseph-Vögele-Str. 1  
67075 Ludwigshafen  
Germany

T: +49 621 8105-0

F: +49 621 8105-461

E: [marketing@voegele.info](mailto:marketing@voegele.info)

 [www.voegele.info](http://www.voegele.info)



For more information scan the code.